

A Falling Plate Meter for Estimating Pasture Forage Mass

Ed Rayburn, *WVU Extension Forage Agronomist*
John Lozier, *WVU Research Assistant III*

Nov. 2003

Background

It is often helpful to have a reliable estimate of forage on offer to grazing livestock. Research has shown that there is a high correlation between forage height and dry matter yield. This correlation is improved when bulk height is determined by depressing the forage with a weighted plate. This weighted plate technique referred to as a weighted disk meter, appears to improve the estimate of pasture yield. Different designs of weighted disk meters are called rising plate meters and falling plate meters depending on how measurements are taken. The weighted disk meter described here is a falling plate meter.

Weighted disk meters are generally made of sheet metal using an etched metal measuring rod. Researchers have used modifications of this design to establish the effect of size and area weight on the performance of these meters. Based on this research, an inexpensive weighted disk meter was made from acrylic plastic for use in conducting on-farm research and demonstration programs.

Material

The material needed for a practical pasture plate has to meet the following requirements: it must be readily available in standard stock across the region, it must be stable in weight per unit area when exposed to moisture in the air and on the forage, and it must be relatively inexpensive. Acrylic plastic sheeting meets all these requirements.

A square of acrylic plastic measuring 0.22 inches thick and 18 inches square was chosen. This thickness has a weight per area (1.47 lb./sq. ft.) that results in good prediction of dry matter yield and is inexpensive. The cost of the 18-inch plate was about \$15 (2002). When used with a yardstick, this makes an inexpensive and serviceable falling plate meter for estimating forage yields.

Construction

The falling plate meter is made from 0.22-inch acrylic plastic sheeting cut in an 18-inch square. A 1.5-inch hole is cut in the center of the plate. A yardstick is used for measuring the plate's height above the ground when it is set on the sward. The edges of the center hole need to be smoothed with a wood rasp to prevent rough edges from catching on the yardstick.

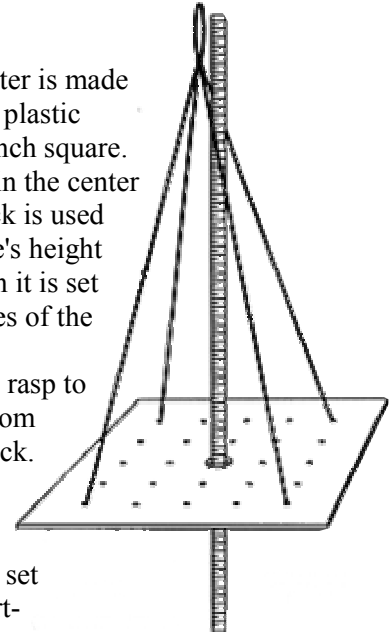

In addition 24, 0.125-inch holes are drilled along five lines set at 3-inch intervals, starting 3 inches from the plate's edge. Holes are spaced at 3-inch intervals along these lines, again starting 3 inches from the edge. This results in 24 holes (the 25th hole being in the yardstick hole). These holes can be used for estimating ground covered in thin stands and in grazed stubble.

The yardstick should be connected to the plate so that the two can be carried as one unit. One way to do this is to tie a string through two or four of the small holes in the plate. Tie a loop at the top of the string, and hold the loop in the hand that is holding the yardstick. The user then places the tip of the yardstick on the ground and lowers the plate gently to the surface of the forage canopy. [Click here for construction details.](#)

Use

Use the plate meter by walking the pasture, selecting a location at random, and placing the plate gently on the forage until it supports the plate. Measure the height of the plate's top above the ground. Placing the plate on the forage is more satisfactory than dropping

the plate from a standard height. We found that dropping the plate is not practical on hills or on windy days.

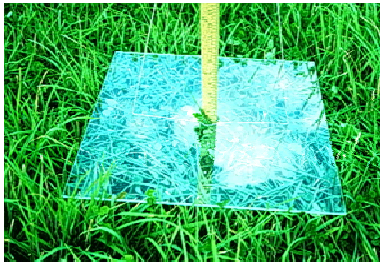

Figure 1. The plate meter and yardstick using a looped string so that the plate and yardstick can be held in one hand. ([Click here for enlarged view](#)).

To achieve a good estimate of the forage mass in a pasture, you must measure enough points. The reliability of the mean pasture height increases as the number of samples increases to 20 or 30, with a little improvement as the sample size increases to 50. Our recommendation is to take at least 30 bulk height measurements per pasture.

When selecting the sample location the user should be careful not to bias the average by choosing more productive areas over less productive areas. Sample to get a representative sample over the pasture. When the general area is reached, the sample point should be taken at random. If the sample point has old seed heads or large weeds, which will bias the plate height, move the plate to one side to miss the obstruction. When used in well-managed, rotationally-grazed or clipped pastures this is not a major problem.

Calibration

Calibration equations for the pasture plate may vary due to species, season, and location. For calibration we use a square wire frame that just fits over the pasture plate. The frame is set over the sample site and the plate removed. The forage is then separated so that the frame lies on the ground. The forage is cut as close to ground level as possible with battery-powered lawn edgers. The forage is weighed wet in the field using lightweight spring scales and composited for dry matter determination. Regression equations are calculated from the measured bulk height and dry matter yield using a scientific calculator.

An alternative to calibration is to calculate the forage density at each sample point by dividing dry forage mass (lb/a) by the plate height of the sample. Density is then lbs dry matter/acre/inch plate Ht. Then average these densities for all the paired clipped samplings.

Testing

The pasture plate has been used extensively in pasture sampling from 1986 through 2003 on cool-season grass-legume pastures managed under intensive rotational grazing. These pastures include orchard grass, timothy, quackgrass, bluegrass, ryegrass, white clover, and red clover stands. An average calibration for estimating dry matter yield (DMY) from pasture plate height was found to be:

$$\text{DMY lb./a} = 432 \text{ Plate Height (inches)}$$

The fact sheet “Estimating Pasture Forage Mass from Pasture Height” gives more details on general calibrations for use with the falling plate meter, a commercial rising plate meter and ruler measurements of pasture height.

This falling plate meter has been used by farmers over the Northeast as part of the Northeast Dairy Farm Forage Demonstration (a NESARE Project) and as part of other collaborative regional research projects. This plate is as reliable as the more sophisticated metal weight disks meters or expensive electronic probes and provides a practical, low-cost means of extending research recommendations to farmers.

References

1. Bransby, D.I., A.G. Matches and G.F. Krause. 1977. *Disk meter for rapid estimation of herbage yield in grazing trials*. *Agronomy Journal*. 69:393-396.
2. Griggs, T.C. and W.C. Stringer. 1988. *Prediction of alfalfa herbage mass using sward height, ground cover and disk technique*. *Agronomy Journal*. 80:204-208.
3. Michalk, D.L. and P.K. Herbert. 1977. *Assessment of four techniques for estimating yield on dryland pastures*. *Agronomy Journal*. 69:864-868.
4. Varth, E.W. and A.G. Matches. 1977. *Use of a weighted-disk measure as an aid in sampling the herbage yield on tall fescue pastures grazed by cattle*. *Agronomy Journal*. 69:888-890.

